

Chêne
Bois massif « pris à cœur », finition sablée

Version finition laque satinée

—

Oak
Heart wood, sandblasted finish

Version satin lacquer finish

—

Eiche
Massivholz, gesandstrahlt

Version farbig satiniert lackiert

—

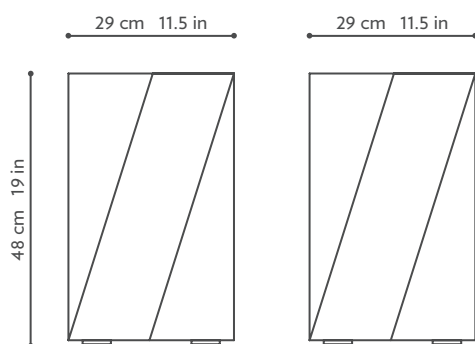

Chêne

Plateau en verre feuilleté bronze, 19 mm d'épaisseur
 Décor rapporté sur plateau en métal tramé Astrid
 Piètement plaqué

Version avec plateau en verre extra-blanc
 et piètement en chêne finition gougée.

—

Oak

Bronze coloured laminated glass top, 19 mm thick
 Astrid textured metal decor laid on glass top
 Veneered base

In extra-clear glass top and oak with
 a gouged finish

—

Eiche

Bronzefarbige Verbundglashplatte, 19 mm dick
 Tischplatte mit Astrid Metalldekor berichtet
 Gestell furniert

Version mit extraweissem Glass
 und Gestell gekehlt Eiche

—

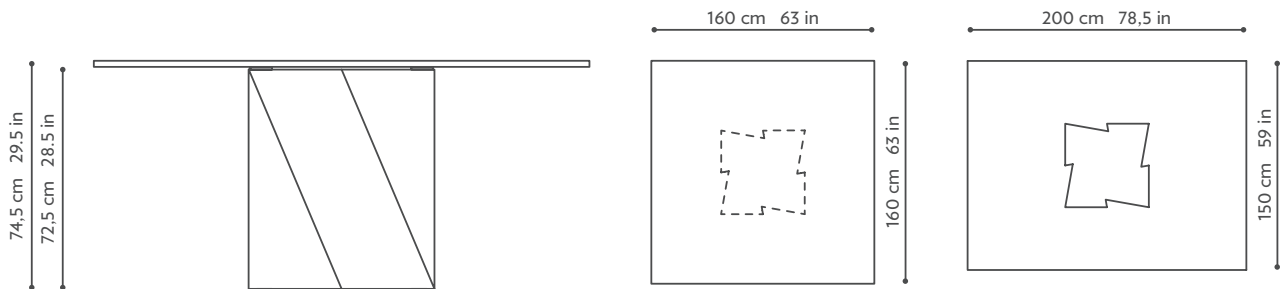

Visuel présenté : plateau en verre feuilleté bronze,
 piètement en chêne sablé Bronze.

Picture on front page: Bronze coloured laminated glass
 top, base in sandblasted oak col. Bronze.

Abgebildetes Modell : Bronzefarbige Verbundglashplatte.
 Gestell in sandgestrahlter Eiche „ Bronze “.

Chêne
Plateau et piètement plaqués

Version plateau en verre extra-blanc laqué,
19 mm d'épaisseur

—

Oak
Veneered top and base

Version Extra-clear lacquered glass top, 19 mm thick

—

Eiche
Tischplatte und Gestell furniert

Version Extra-Klare Glasplatte farbig lackiert, 19 mm

—

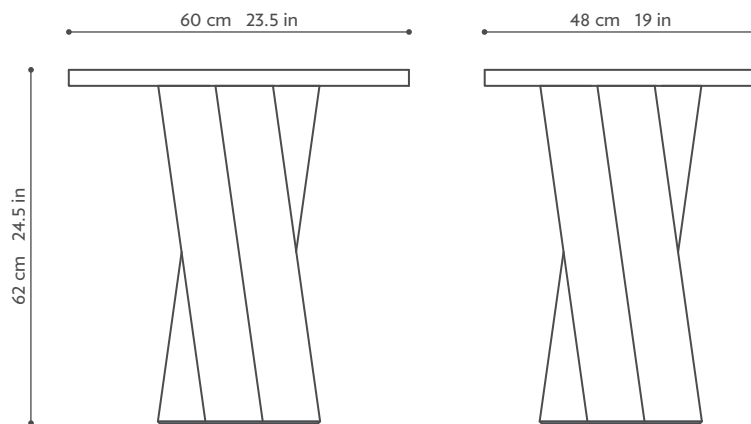

Bronze patiné
Tige en laiton
Abat-jour en toile
Ampoule comprise
—

Bronze with a dark patina finish
Brass stem
Fabric lampshade
Bulb inc.
—

Bronze patiniert
Metall Schaft in Messing
Lampenschirm stoffbezogen
Leuchtmittel inbegriffen
—

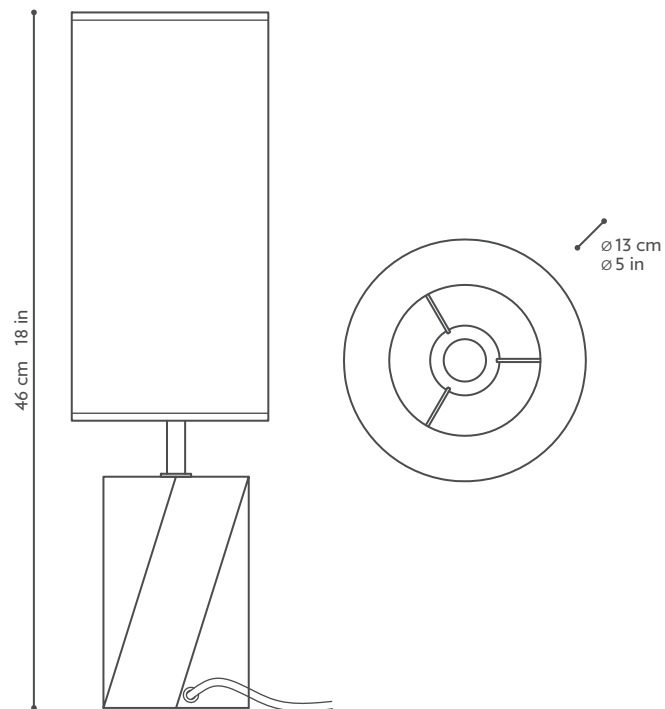

Bronze patiné

—

Bronze with a dark patina finish

—

Bronze patiniert

—

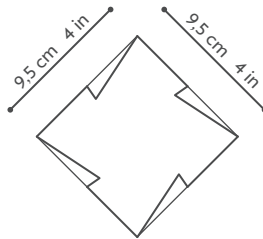
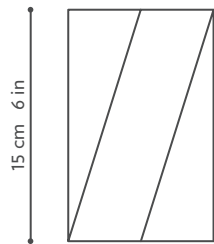

Structure laquée

—

Lacquered frame

—

Struktur lackiert

—

